

# AIRPAX

APG/UPG/IPG  
Magnetic Circuit Protectors

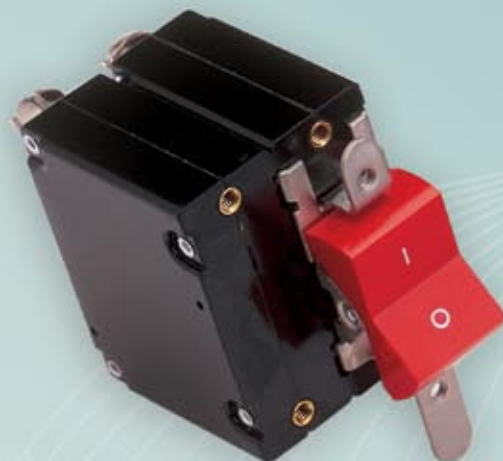



APG/UPG Single Pole Circuit Protectors	115
Multi-Pole Circuit Protectors	116
APGHX/UPGHX Protectors	118
APGX/UPGX Protectors	119
APGN/UPGN Protectors	120
APG/UPG Handles and Actuators	121
IPG Magnetic Circuit Protectors	122
APG/UPG/IPG Configurations	123
APG/UPG/IPG Operating Characteristics	125
APG/UPG/IPG Delay Curves	126
Specifications	130
APG/UPG Decision Tables	132
IPG Decision Tables	134

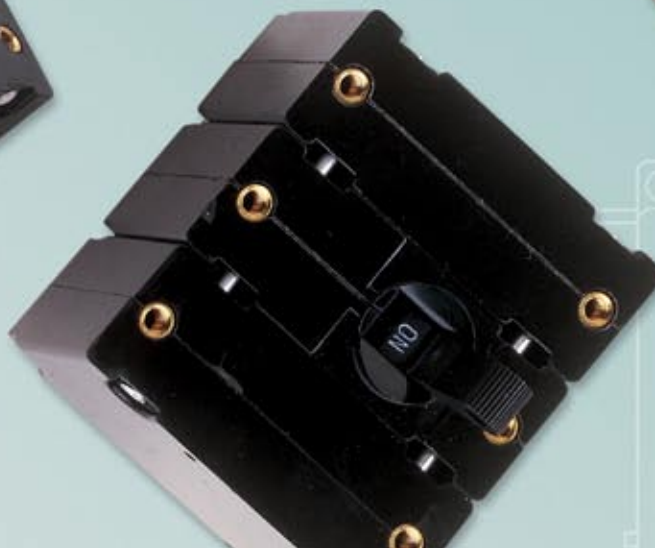
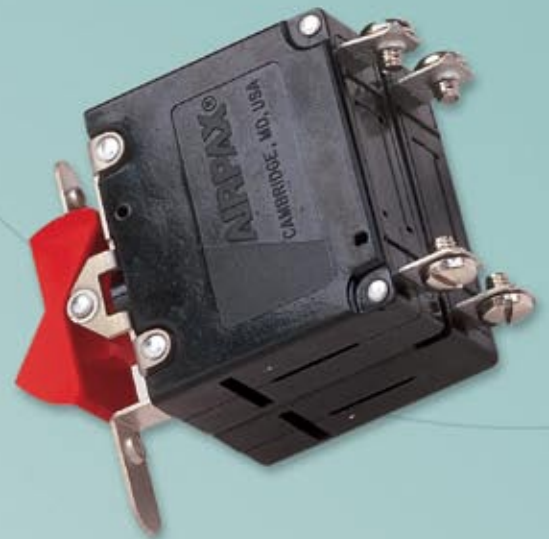

# APG / UPG SINGLE POLE CIRCUIT PROTECTORS

The APG/UPG magnetic circuit protector provides low-cost power switching, reliable circuit protection and accurate circuit control in one complete package. It is intended for use in data processing and broadcast equipment, vending and amusement machines, military and marine applications, and wherever precision operation is required.

Designed using a current sensitive hydraulic magnetic principle, the APG/UPG adapts itself to many applications and environments. Temperature compensations which affect fuses and other thermal devices are not a concern. Nuisance tripping is minimized.

The APG/UPG is available in a wide variety of configurations with a choice of delays and ratings. In addition, it is available in either DC, 50/60Hz or 400Hz versions.

Available in single or multi-pole variations, the APG/UPG comes with a variety of actuators. To enhance front-panel aesthetics, toggle or rocker actuated handles and caps are available in a variety of attractive colors.

Multi-pole circuit protectors can be furnished with either single or multiple actuators. In addition, a unique sealed, single handle toggle version for harsh or military environments is available in single or multi-pole configurations.

The UPG circuit protector is recognized under UL Standard 1077, file numbers E66410 and E33504 as a supplementary protector. It is also certified by CSA under CSA STD. C22.2–No. 235, file number LR26229 as a supplementary protector. The APG is qualified to MIL-PRF-55629.

APG/UPG circuit protectors are available in one through four pole assemblies with a variety of pole arrangements, terminal styles, and accessories to meet your specifications, including APG/UPG adapter plate option to allow mounting in APL/UPL cutout.

## Single Pole, Toggle

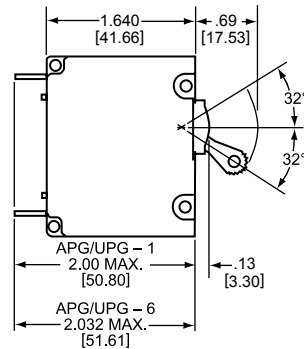

## Single Pole

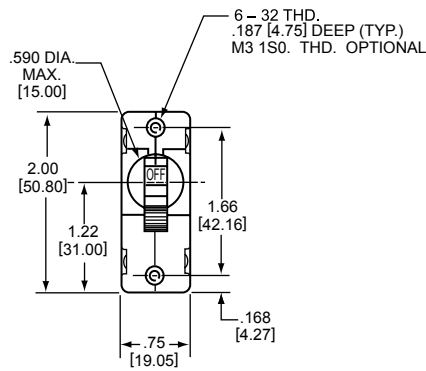

## APG 6-1\*

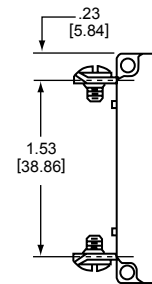

## Single Pole, Mounting Detail

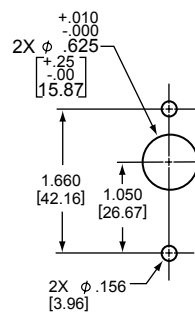

## Adapter Plate\*\* P/N 120-700-1260



## Terminals

Amp Rating	Push-on	8-32	M4	10-32	M5
30A	X	X	X		
> 30A				X	X

**Notes:** Tolerance  $\pm 0.15$  [.38] unless noted.  
Dimensions in Brackets [ ] are millimeters.  
\*\* Allows mounting in APL/UPL cutout.



# MULTI-POLE CIRCUIT PROTECTORS

## Two Pole Protectors

An assembly consisting of two single pole units, having their trip mechanisms internally coupled, and with a single toggle handle, forms the APG/UPG-11. It is also possible to provide a handle per pole, which is referred to as UPGH11. Individual poles may differ in ratings, delays and internal connections. An auxiliary switch may be included in either or both poles if they are of the series trip type. Screw-type terminals can be provided, in which case the designation would be APG/UPG-66.

Two Pole

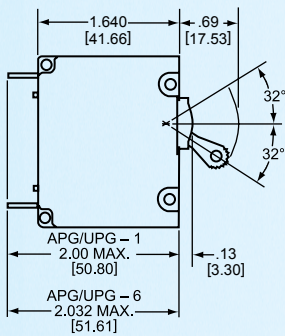

UPG11

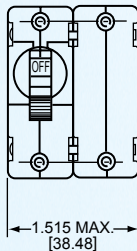

(Optional, handle may be in pole 1 instead of pole 2)

UPGH11

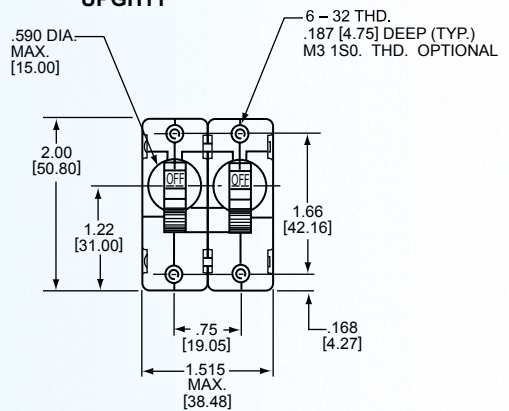

UPG11

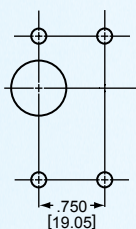

Two Pole\*

UPGH11

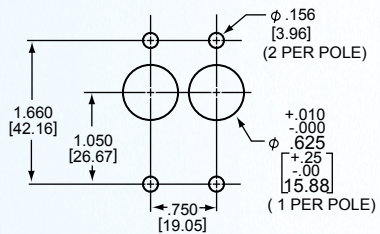

Two Pole

**Panel Mounting Detail:** Tolerance  $\pm .005$  [ .13 ] unless noted.

**Note:** Tolerance  $\pm .015$  [ .38 ] unless noted. Dimensions in Brackets [ ] are millimeters.  
\* See single pole mounting detail for hole sizes and locations.

### Three Pole and Four Pole Protectors

The three pole structure consists of three single pole units assembled with an internal mechanical interlock which actuates all units simultaneously. A single toggle handle operates all three poles, or a handle per pole is available. The four pole structure consists of four single pole units assembled with an internal mechanical interlock which actuates all units simultaneously. A double toggle handle operates all four poles, or a handle per pole is available. The individual poles need not have identical characteristics and any series trip pole may have an auxiliary switch. If screw-type terminals are required, the breaker designation will be APG/UPG-666 for a three pole version and APG/UPG-6666 for a three pole version and APG/UPG-6666 for a four pole version.

Protector poles are numbered consecutively when viewed from the terminal side, with the ON position up, starting with Pole #1 on the left side and proceeding to the right.

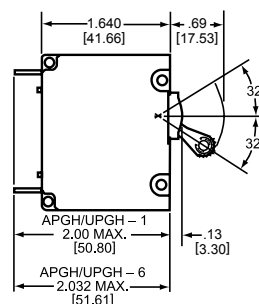

Three Pole

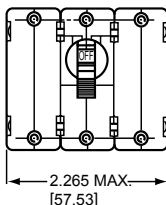

UPG 111

Three Pole

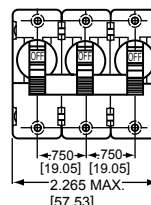

UPGH 111

Mounting Detail

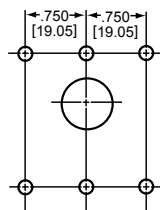

Three Pole\*

Mounting Detail

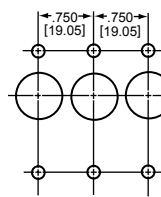

Three Pole\*

\* See single pole mounting detail for hole sizes and locations.

Four Pole

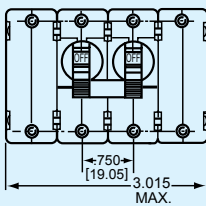

APG/UPG only

Four Pole

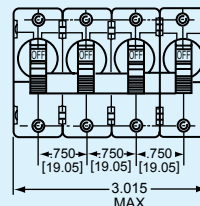

APGH/UPGH only

Mounting Detail

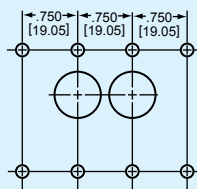

Four Pole\*

Mounting Detail

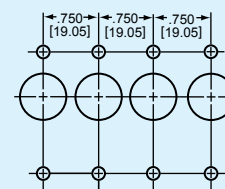

Four Pole\*

APG/UPG/IPG

# APGHX / UPGHX PROTECTORS

## APGHX / UPGHX

Rocker actuated APGHX/UPGHX provides one rocker handle for each pole of a multi-pole circuit protector.

Number of Poles	Dimension "A"
2 Pole	1.510 ± .005 [38.35±.13]
3 Pole	2.265±.005 [57.53±.13]

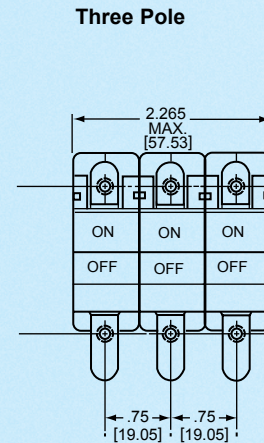
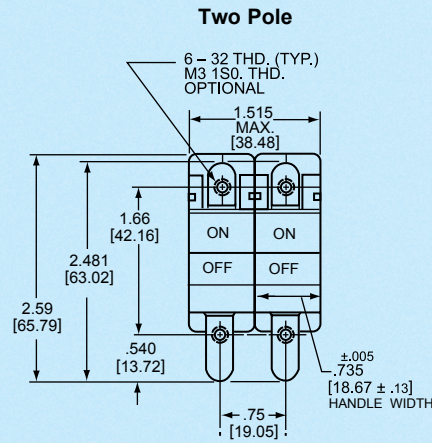
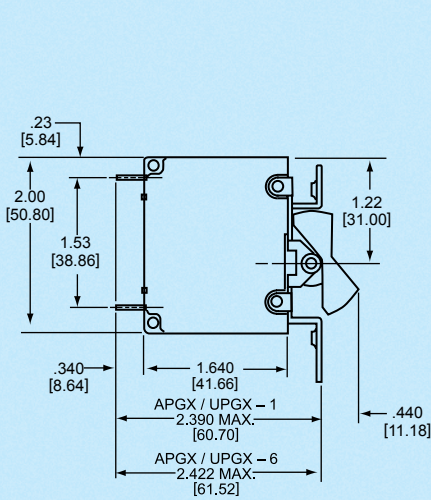

**Panel Mounting Detail:**  
Tolerance ±.005 [.13] unless noted.

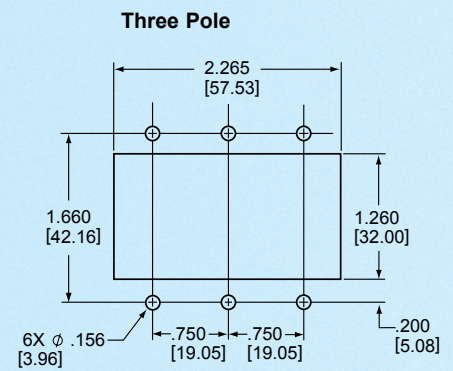
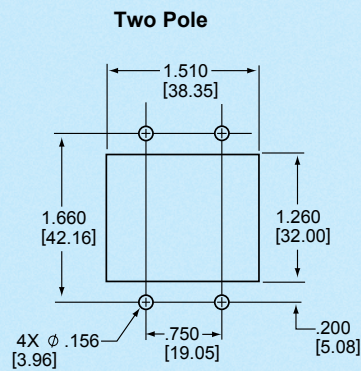

APG/UPG/IPG

**APGX / UPGX**

Rocker actuated APGX / UPGX provides one rocker handle per circuit protector.

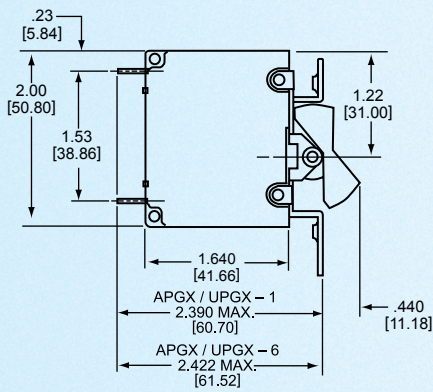

**Single Pole**

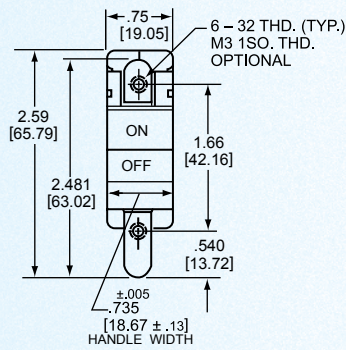

**Two Pole**

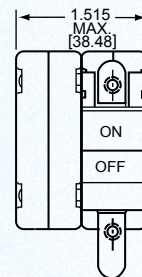

(Optional, handle may be in pole 2 instead of pole 1)

**Three Pole**

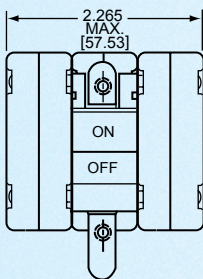

**One, Two & Three Pole**

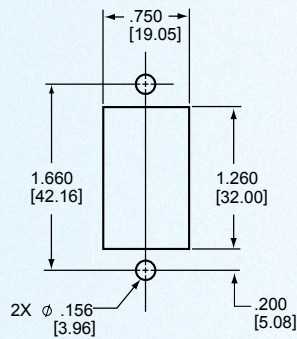

**Panel Mounting Detail:**  
Tolerance  $\pm .005$  [.13] unless noted.

**Note:** Tolerance  $\pm .015$  [.38] unless noted.  
Dimensions in Brackets [ ] are millimeters.

# APGN / UPGN PROTECTORS

## Bat Handle / Panel Seal (APGN / UPGN)

The APGN is designated to provide circuit protection in harsh and military environments. Waterproof panel integrity is provided by an "O" ring bushing seal and silicon rubber gland within the bushing/handle assembly. Single, two or three pole versions are available with two and three pole versions featuring a single operating handle and mounting bushing.

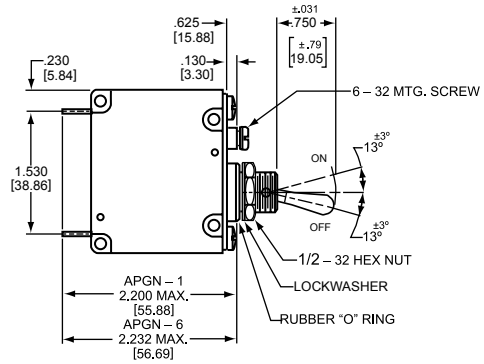

### Single Pole

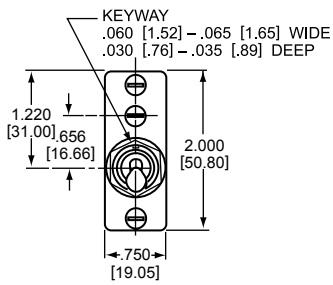

### Two Pole

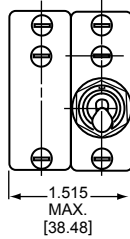

(Optional handle may be in pole 2 instead of pole 1)

### Three Pole

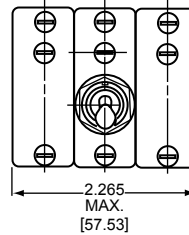

### Single Pole

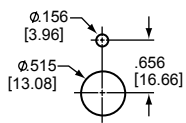

### Panel Mounting Detail:

Mounting detail tolerance ±.005 [.13] unless noted.

\*See single pole mounting detail for hole sizes and locations.

### Two Pole\*

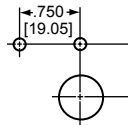

### Three Pole\*

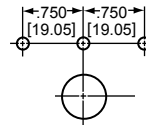

### Optional Handle

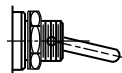

**Standard Handle Location**  
(Applies to 2 Pole Only)

**Toggle Handles**

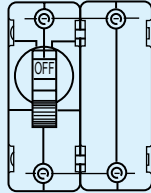

APG/UPG

**Bat Handle/  
Panel Seal**

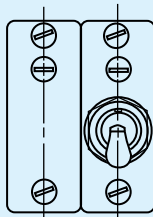

APGN/UPGN

**Rocker**

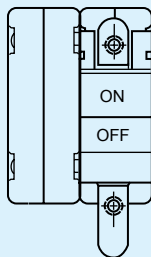

APGX/UPGX

**Toggle Handles**

The APG/UPG circuit protector is available with toggle handles in six different colors. For attractive panel appearance, color caps are also available. Handles may be specified in black, white, yellow, red, blue and green. For multi-pole units, specify handle per unit or handle per pole.

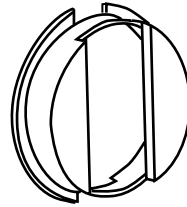

**Color Caps**

For attractive panel appearance the following color caps are available for use on APG/UPG protectors.

Color Caps	Order Separately
Red	762 - 300 - 8046
Green	762 - 300 - 8043
White	762 - 300 - 8040
Gray	762 - 300 - 8041
Blue	762 - 300 - 8042
Yellow	762 - 300 - 8044
Orange	762 - 300 - 8045
Brown	762 - 300 - 8047
Black	762 - 300 - 8048

**Note:** Tolerance  $\pm .015$  [.38] unless noted.  
Dimensions in Brackets [ ] are millimeters.

# IPG MAGNETIC CIRCUIT PROTECTORS

The IPG circuit protectors provide the advantages of magnetic “stand alone” protection and compliance with UL, CSA, SEV, VDE and IEC standards.

They are UL Recognized per UL STD. 1077 as supplementary protectors, CSA Certified per CSA C22.2–No. 235 as supplementary protectors, VDE approved and CE compliant to VDE 0642 (EN60934).

Additionally, they conform to the spacing requirements of VDE 0730, 0804, 0805 and 0806, and IEC 950 for use in office machines and data processing equipment.

IPG circuit protectors have current ratings from .020 to 50 amperes, 250Vac, 65Vdc, and an auxiliary switch is available with either gold or silver contacts. They feature one through four pole configurations, with one handle per pole. A choice of handle actuation colors, terminals and hardware are available and international markings are standard. And, with an adapter plate, they will fit in panels cut for Airpax APL and UPL type protectors.

**Note:**

Main terminals are stationary male push-on type .250 [6.35] wide x .031 [.787] thick x .312 [7.92] long or 8-32 x .187 [4.75] screw type (≤30A). 10-32 x .187 [4.75] screw type (>30A).

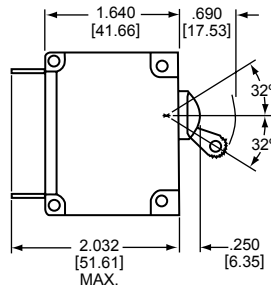

**Single Pole**

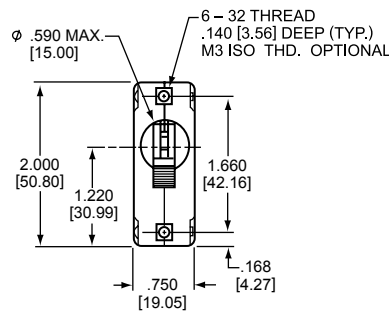

**Two Pole**

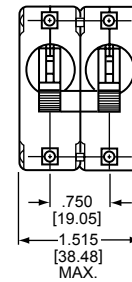

**Three Pole**

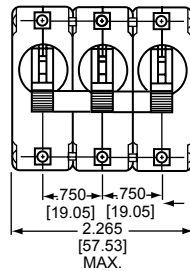

**Four Pole**

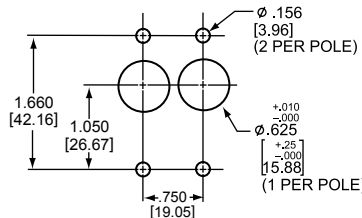
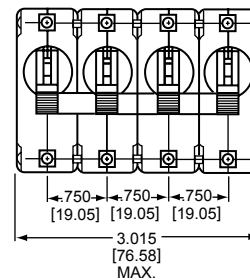

**Panel mounting detail:**

Tolerance ± .005 [.13] unless noted.

APG/IJPG/IPG

**Series and Switch Only**

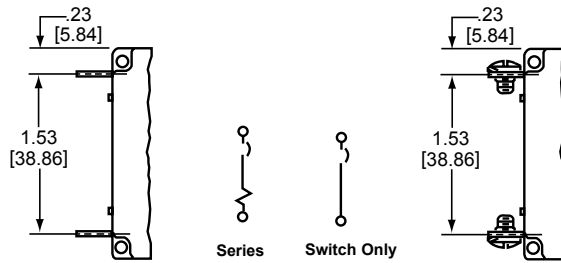

**Series Trip**

The most popular configuration for magnetic protectors is the series trip where the sensing coil and contacts are in series with the load being protected. The handle position conveniently indicates circuit status. In addition to providing conventional overcurrent protection, it's simultaneously used as an on-off switch.

**Shunt and Dual Coil**

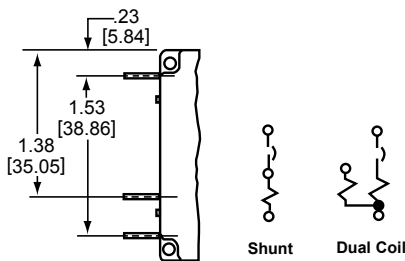

**Shunt Trip**

The shunt trip is designed for controlling two separate loads with one assembly. The control is established by providing overload protection for the critical load. When the current through this load becomes excessive and reaches the trip point, the protector will open and remove power from both loads simultaneously. The total current rating of both loads must not exceed the maximum contact rating.

**Tapped Coil**

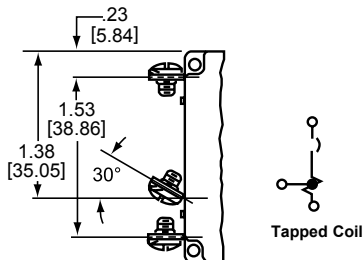

**Note:** Tolerance  $\pm .015$  [.38] unless noted.  
Dimensions in Brackets [ ] are millimeters.

**Relay Trip**

This permits the overload sensing coil to be placed in a circuit which is electrically isolated from the trip contacts. The coil may be actuated by sensors monitoring pressure, flow, temperature, speed, etc. Other typical applications include crowbar, interlock and emergency/rapid shutdown circuitry. Trip may be accomplished by voltage or current, which must be removed after trip.

**Relay and Dual Coil**

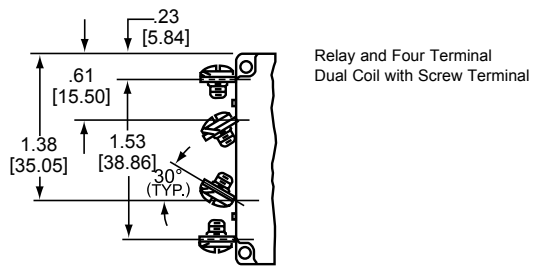
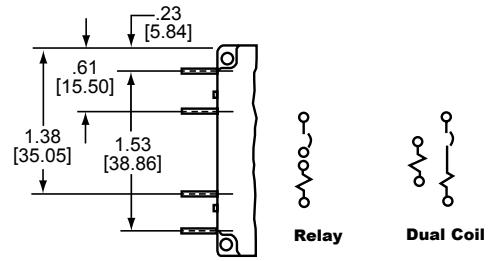

**Auxiliary Switch**

This is furnished as an integral part of a series pole in single or multi-pole assemblies. Isolated electrically from the protector's circuit, the switch works in unison with the power contacts and provides indication at a remote location of the protector's on-off status.

**Voltage Trip**

Sometimes called "dump circuits" or "panic trip circuits," these units make it possible to open main power contacts with lower power inputs from one or more sources. This configuration is becoming increasingly more important for sensitive circuitry and denser packaging in automation systems. Available in series, shunt, or relay configurations.

**Auxiliary Switch**

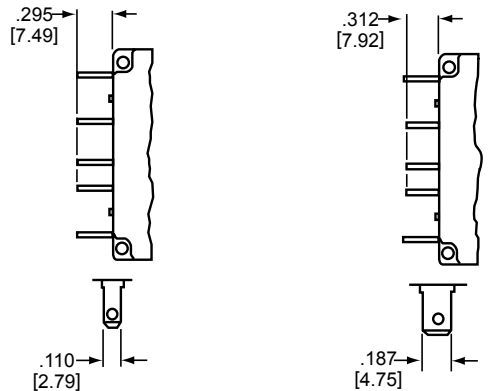

-1 REC 4  
-1 REG 4  
Quick Connect  
Terminals

-1 REC 5  
-1 REG 5  
Quick Connect  
Terminals

Series with Auxiliary Switch  
All auxiliary switch terminals  
.020[.51] thick  
Standard auxiliary switch is REC 4.

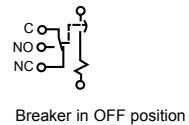

**Note:**

Main terminals are stationary male push-on type .250 [6.35] wide, x .031 [.787] thick, x .312 [7.92] long or 8-32 x [4.75] screw type (≤30A), 10-32 x .187 [4.75] screw type (>30A).

**Note:**

Tolerance ± .015 [.38] unless noted. Dimensions in Brackets [ ] are millimeters.

# APG/UPG/IPG OPERATING CHARACTERISTICS

## Nominal DCR and Impedance

Current Ratings in Amperes	DC Delays				50/60Hz Delays				400Hz Delays	
	Resistance in Ohms				Impedance in Ohms				Impedance in Ohms	
	50	59	51-52 53	Dual Coil 51-52 53	60	69	600 61-62 71-72-73	64-65-66 Dual Coil 61-62	40-49	41-42 43
.05	162.	540.	460.	640.	174.	419.	582.	691.	1975.	1195.
.10	35.4	105.	155.	150.	42.5	103.4	119.0	160.	495.	284.
.50	1.2	4.2	4.5	5.6	1.9	4.	4.1	6.2	22.	12.
1.	.236	1.02	1.2	1.41	.41	.955	1.08	1.56	5.01	2.72
5.	.021	.048	.059	.070	.030	.045	.048	.068	.240	.140
10.	.0060	.0121	.0140	.0160	.0075	.0105	.0134	.0174	.0520	.0283
15.	.0040	.0067	.0092	.0100	.0038	.0068	.0070	.0120	.0260	.0140
20.	.0032	.0047	.0052	.0070	.0024	.0049	.0050	.0069	.0140	.0088
30.	.0021	.0036	.0036	.0040	.0022	.0032	.0035	.0037	.0079	.0043
50.	.0020	.0024	.0026	.0023	.0020	.0020	.0025	.0030	.0036	.0028

**Notes:** DCR and impedance based on 100% rated current applied and stabilized a minimum of one hour.  
**Tolerance:** .02 amperes to 2.5 amperes, ± 20%; 2.6 amperes to 20 amperes, ± 25%; 21 amperes to 50 amperes, ± 50%. Consult factory for special values and for coil impedance of delays not shown.

## Percentage Overload vs. Trip Time in Seconds

Delay	100%	125% (Note A)	150%	200%	400%	600%	800%	1000%
40	No Trip	May Trip	.040 Max.	.035 Max.	.030 Max.	.025 Max.	.020 Max.	.018 Max.
41	No Trip	May Trip	.5 - 8	.15 - 1.9	.02 - .4	.006 - .25	.004 - .1	.004 - .05
42	No Trip	May Trip	5 - 70	2.2 - 25	.40 - 5	.012 - 2	.006 - .2	.006 - .15
49	No Trip	.150 Max.	.100 Max.	.032 Max.	.020 Max.	.020 Max.	.020 Max.	.020 Max.
43 & 400	No Trip	May Trip	35 - 350	12 - 120	1.5 - 20	.1 - 4	.01 - .250	.009 - .100
50	No Trip	May Trip	.032 Max.	.024 Max.	.020 Max.	.018 Max.	.016 Max.	.015 Max.
51	No Trip	.5-6.5	.3 - 3	.1 - 1.2	.031 - 5	.011 - .25	.004 - .1	.004 - .08
52	No Trip	2-60	1.8 - 30	1 - 10	.15 - 2	.04 - 1	.008 - .5	.006 - .1
59	No Trip	.100 Max.	.070 Max.	.032 Max.	.020 Max.	.020 Max.	.020 Max.	.020 Max.
53 & 500	No Trip	80 - 700	40 - 400	15 - 150	2 - 20	.7 - 10	.1 - 3	.010 - .100
60	No Trip	May Trip	.040 Max.	.035 Max.	.030 Max.	.025 Max.	.020 Max.	.018 Max.
61	No Trip	.7 - 12	.35 - 7	130 - 3	.030 - 1	.015 - .3	.01 - .15	.008 - .1
62	No Trip	10 - 120	6 - 60	2 - 20	.2 - 3	.02 - 2	.015 - .8	.01 - .25
64	No Trip	.7-10	.35 - 6	.15 - 3	.05 - .6	.025 - .3	.020 - .22	.015 - .15
65	No Trip	7 - 90	3 - 40	1 - 12	.2 - 3	.08 - 1	.03 - .7	.016 - .3
66	No Trip	50 - 700	30 - 400	10 - 150	1.5 - 20	4 - 10	.05 - 3	.02 - 2
69	No Trip	.120 Max.	.100 Max.	.050 Max.	.022 Max.	.017 Max.	.017 Max.	.017 Max.
600	No Trip	80 - 700	45 - 400	15 - 150	2 - 20	2 - 4	.025 - 1	.01 - .2

**Notes:** All trip curves and trip currents are specified with the protector mounted in the normal vertical position at ambient temperature of +25° C. Protectors do not carry current prior to application of overload. **A:** Ratings above 30 amps may deviate from the above limits by approximately 10% (130% for delay 49).

For dual frequency curves, see page 116.

# APG/UPG/IPG OPERATING CHARACTERISTICS AND DELAY CURVES

## Dual Frequency (DC/60Hz)

Delay	100%	135%	150%	200%	400%	600%	800%	1000%
71	No Trip	.4 - 14	.2 - 7	.1 - 3	.027 - 1	.015 - .3	.01 - .15	.008 - .1
72	No Trip	7-130	3 - 60	1.3 - 20	.085 - 3	.02 - 2	.015 - .8	.01 - .26
73	No Trip	50-700	30 - 400	10 - 150	.8 - 20	.14 - 4	.025 - 1	.01 - .26

**Notes:** All trip curves and trip currents are specified with the protector mounted in the normal vertical position at ambient temperature of +25 C. Protectors do not carry current prior to application of overload.

## Inrush Pulse Tolerance

It can be seen that the 64, 65 and 66 delays have a high inrush capability and for most applications an inertia wheel would not be required. Pulse tolerance is defined as a single pulse of half sine wave peak current amplitude of 8 milliseconds duration that will not trip the circuit breaker.

Delay	Pulse Tolerance
61, 62	10 times rated current
61F, 62F	20 times rated current
64, 65, 66	20 times rated current
64F, 65F, 66F	35 times rated current

**Note:** These limits do not apply to dual coil and tapped coil units.

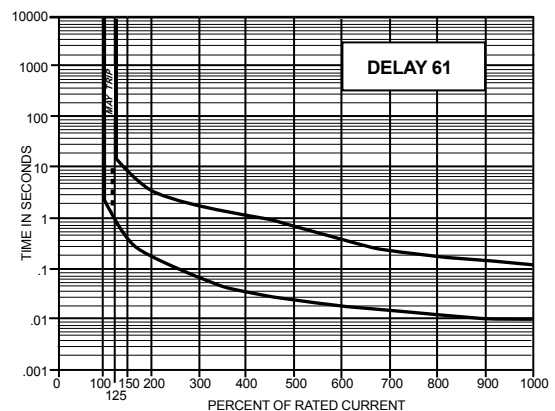
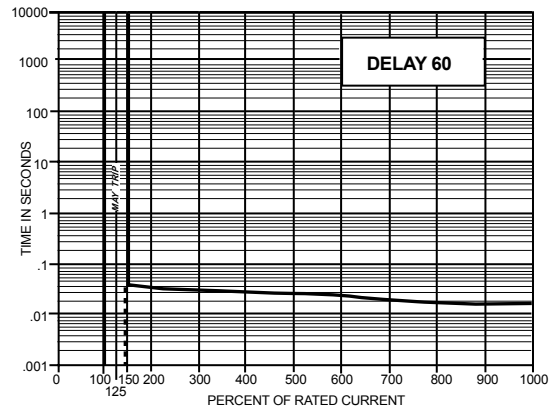

## 50/60Hz Delay Curves (typ)

A choice of delays is offered for DC, 50/60Hz, and 400 Hz applications. Delays 40, 50, 60, 49, 59 and 69 provide fast-acting, instantaneous trip and are often used to protect sensitive electronic equipment (not recommended where known inrush exists). Delays 41, 51, 61 and 71 have a short delay for general purpose applications. Delays 42, 52 and 62 are long enough to start certain types of motors and most transformer and capacitor loads. Delays 43, 53 and 63 are long delays for special motor applications at 400Hz DC and 50/60Hz.

50/60Hz Delay Curves (typ)

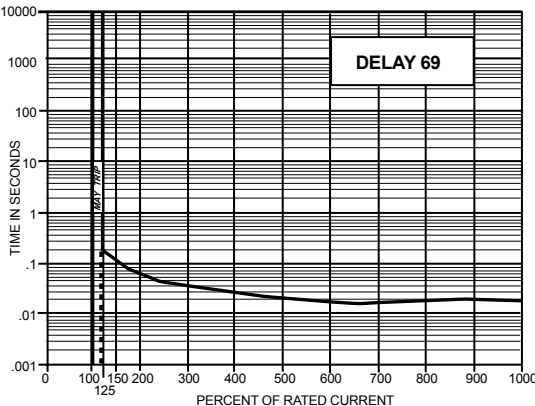
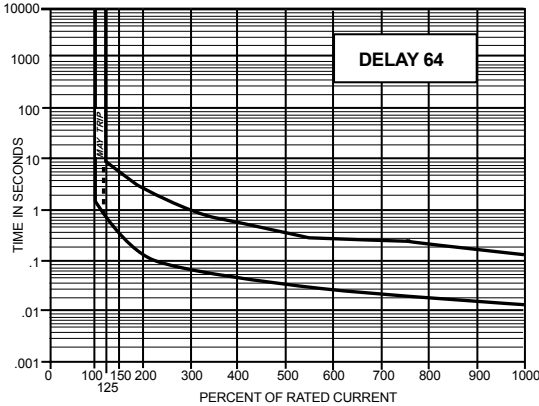
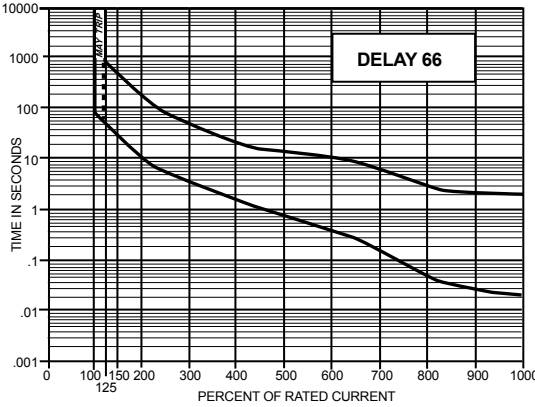
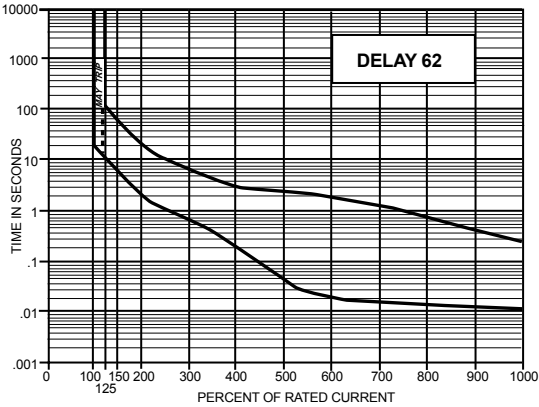
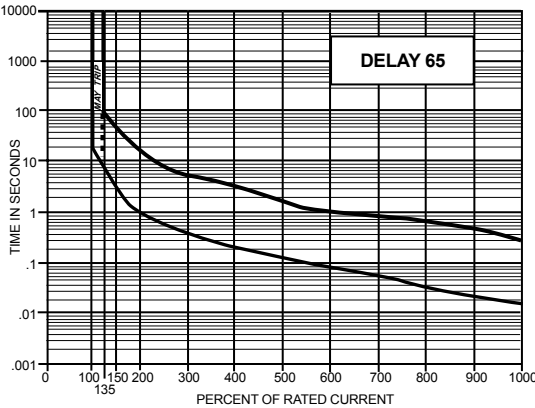

APG/UPG/IPG

# APG/UPG/IPG DELAY CURVES

## DC Delay Curves (typ)

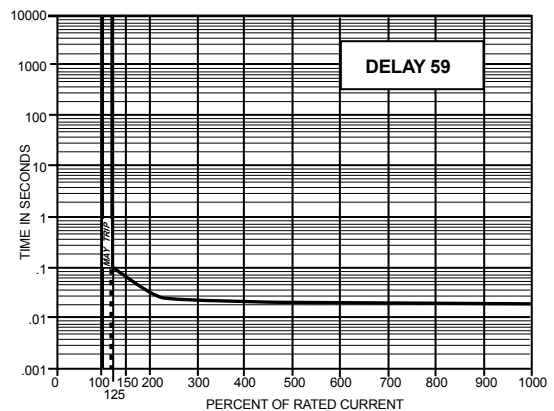
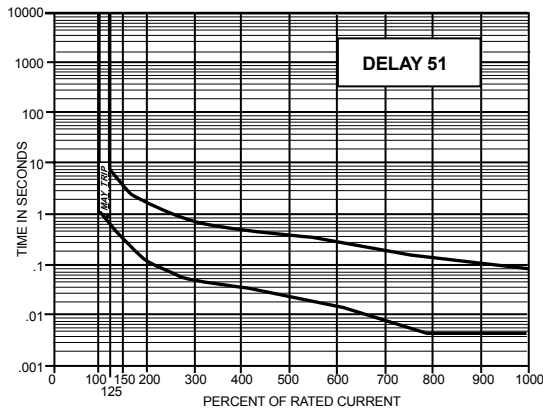
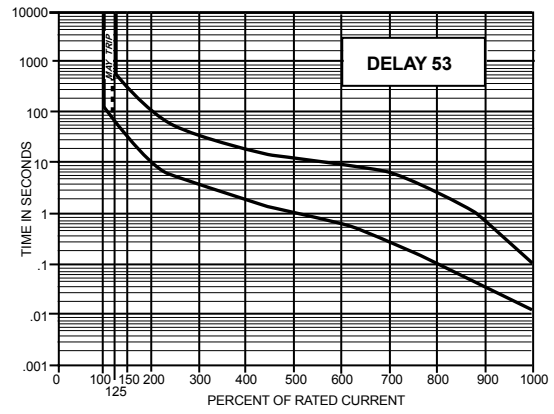
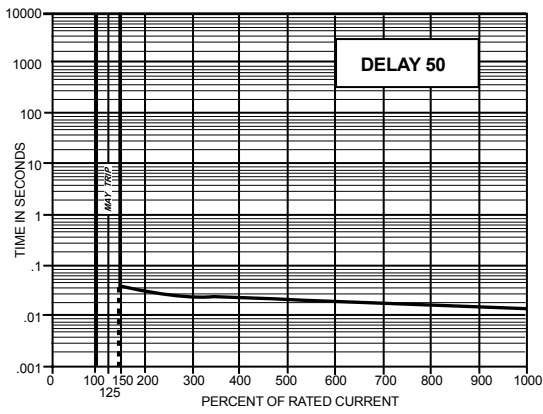
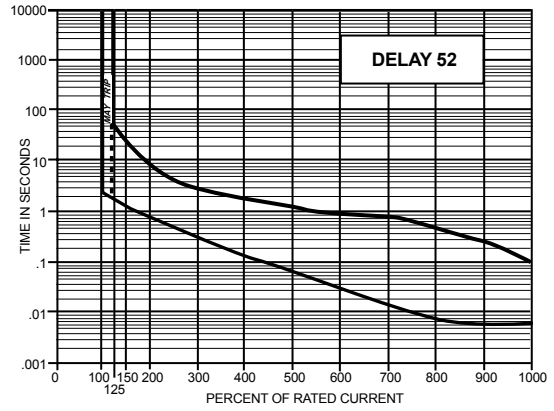

APG/UPG/IPG

400Hz Delay Curves (typ)

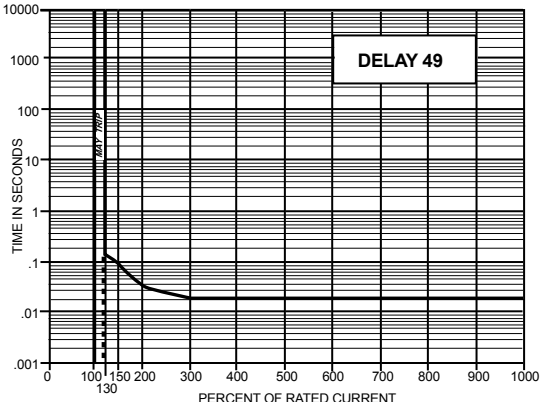
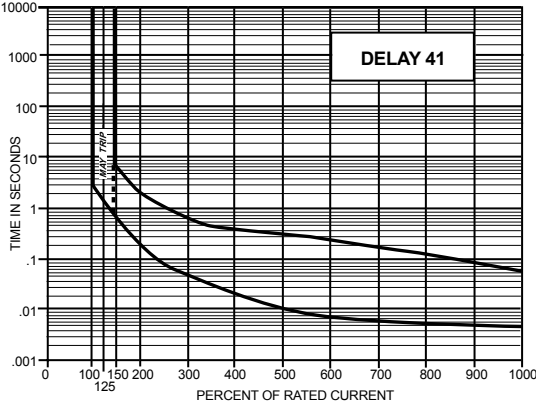
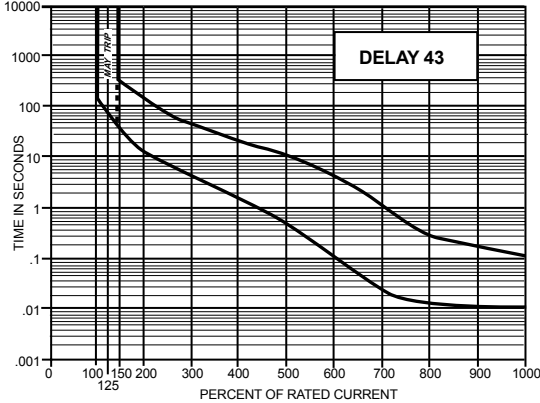
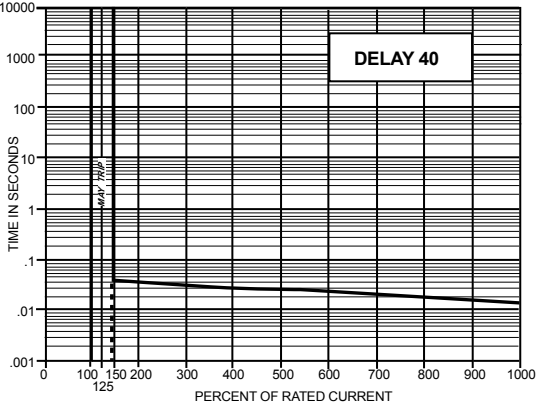
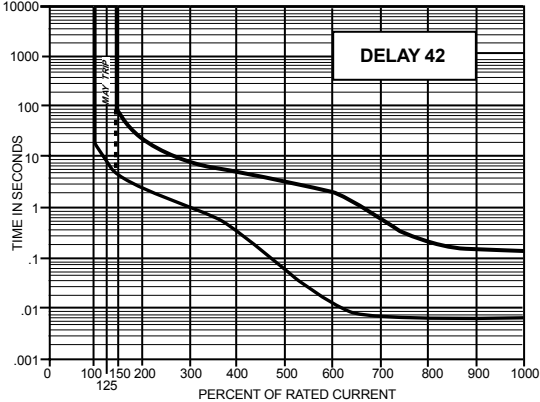

APG/UPG/IPG

# SPECIFICATIONS

### Trip Free

Will trip open on overload, even when forcibly held in the ON position.

### Trip Indication

The operating handle moves positively to the OFF position on overload.

### Ambient Operation

APG/UPG protectors operate normally in temperatures between -40°C and +85°C.

### Auxiliary Switch Ratings

Silver			
3.0 AMP	@	120Vac	—
1.5 AMP	@	—	32Vdc
Gold			
.100 AMP	@	32Vac	32Vdc

### Insulation Resistance

Not less than 100 megohms at 500Vdc.

### Dielectric Strength

APG/UPG/IPG protectors withstand 1500 volts, 60Hz for 60 seconds between all electrically isolated terminals.

Except auxiliary switch terminals shall withstand 600 Volts at 60Hz.

### Endurance

Withstands 10,000 operations at rated voltage and current or withstands 50 operations of 600% AC or 1000% DC rated current at rated voltage followed by 6000 operations at rated voltage and current, in accordance with UL 1077.

### Agency Approvals

Voltage (V)				Rated Current (A) Minimum/Maximum		Interrupting Capacity (A)	
Maximum Rating (V)	Frequency (Hz)	Phase	Minimum Poles	UL/CSA	UL1077/CSA	Maximum Series Fuse	
32	DC	-	1	.05 - 50	2500	none	
65	DC	-	1	.05 - 30	2000	none	
130	DC	-	2	.05 - 15	1000	none	
120	50/60	1	1	.05 - 50	3600	200	
120/240	50/60	1	2	.05 - 50	1000	none	
240	50/60	1 & 3	1	.05 - 10	5000	40	
250	50/60	1 & 3	1	.05 - 50	1000	none	
250	50/60	1 & 3	1	.05 - 50	3650	80	
277	50/60	1	1	.05 - 30	1000	120	
277	50/60	1	1	.05 - 10	5000	40	
125	400	1	1	.05 - 30	2000	none	
240	400	1 & 3	1	.05 - 20	2100	80	
250	400	1 & 3	1	.05 - 30	1000	none	
250	400	1 & 3	1	.05 - 30	3500	125	
277	400	1	1	.05 - 20	1000	80	

**Note:** Series fuse to be a branch-circuit UL approved type K-5 back-up fuse rated at not more than four times the rating of the highest-rated type UPG (15 amperes minimum).

APG/UPG/IPG

**Moisture Resistance**

Meets all the requirements of MIL-PRF-55629 when tested in accordance with Method 106 of MIL-Std. 202.

**Salt Spray (Corrosion)**

Meets requirements of MIL-PRF-55629 when tested in accordance with Method 101 of MIL-Std. 202.

All APG/UPG protectors are constructed with stainless steel springs and plated parts. In addition to meeting normal requirements for moisture and salt spray resistance, the protector meets the fungus resistance requirements of MIL-PRF-55629.

**Poles**

One through four poles with the UPGH, one through three poles with all other types.

**MIL-PRF-55629 (APG)**

Single, two and three pole versions, with and without the auxiliary switch option, have been qualified to MIL-PRF-55629.

**Construction**

Series, shunt, relay, dual coil, tapped coil, voltage trip, no-voltage trip, auxiliary switch, switch only. Various delays and combinations.

**Shock**

Withstands 100G or more without tripping while carrying full rated current per MIL-Std. 202, Method 213, Test Condition I. Instant trip protectors are tested at 80% of rated current.

**Vibration**

Withstands 10G without tripping while carrying full rated current per MIL-Std. 202, Method 204, Test Condition A. Instant trip protectors are tested at 80% of rated current.

**Approximate Weight Per Pole**

	Ounces	Grams
APG/UPG/IPG	2.2	60.5
APGN/UPGN	3.0	76.2

**Recommended Torque Specifications**

6-32 mounting inserts	6 - 8 inch pounds
M3 mounting inserts	4 - 5 inch pounds
8 - 32 screw terminals	10 - 12 inch pounds
M4 screw terminals	10 - 12 inch pounds
10 - 32 screw terminals	14 - 15 inch pounds
M5 screw terminals	14 - 15 inch pounds
½ - 32 mounting bushing	30 - 35 inch pounds

## APG / UPG DECISION TABLES

### How to Order

The ordering code for APG/UPG circuit protectors may be determined by following the steps in the decision tables shown here.

The coding given permits a self-assigning part number but with certain limitations. Units with mixed ratings, combinations of styles, or constructions not listed in the third decision table, require a factory-assigned part number. With these, it is suggested that order entry be by description and/or drawings, and a part number will be established. Additionally, it is standard policy to establish a factory-assigned part number whenever a descriptive drawing exists to provide cross reference, traceability and manufacturing control.

When specifying a circuit protector for AC motor start or high inrush applications, the peak amplitude and surge duration should be specified for factory assistance in rating selection.

For example, the following is the code for a single pole UPG, quick-connect type terminal series unit with auxiliary switch, designed for operation in a 50/60Hz circuit. It has a short time delay and a rating of 20 amperes. A white handle is specified by the seventh decision table.

To determine the ordering number for your particular APG/UPG unit, simply follow the steps shown. You may use this number to place an order or as a reference for further questions you may have.

### Notes:

- A** It is recommended that power leads be soldered to protectors having quick-connect terminals for current trip ratings above 10 amperes.
- B** The standard current values for 100% of rated current are listed. Please consult an Airpax office or sales representative for other values.
- C** UL recognized and CSA certified applications above 30 amperes are restricted to loads having a power factor of 75 minimum and limited to 32Vdc only. Standard terminals on ratings over 30 amperes are 10-32 screw type.
- D** Four pole protectors are available only in the APGH/UPGH and APG/UPG types. The APGH/UPGH four pole provides one handle per pole, while the APG/UPG four pole has handles in the center two poles only, for simplified mounting.
- E** Sub panel mount available in APGX/UPGX configuration only.
- F** When "A" is specified in the sixth decision in conjunction with APG/UPG-6 type, metric screw terminals are supplied.
- G** If a circuit breaker is marked in this manner, it means 277V per pole – single phase source. Thus, if a two or three pole unit is marked 277V, all line terminals must be connected to the same phase, assuming the 277V is taken from line to neutral of 3 phase 277/480V system.

1 First Decision	
Type	
Type	Description
APG	One handle per unit
UPG	One handle per unit UL Recognized and CSA Certified
APGX	One rocker handle per unit
UPGX	One rocker handle per unit UL Recognized and CSA Certified
APGN	Panel seal (one bat handle per unit)
UPGN	Panel seal (one bat handle per unit) UL Recognized and CSA Certified
APGH	One handle per pole
UPGH	One handle per pole UL Recognized and CSA Certified
APGHX	One rocker handle per pole
UPGHX	One rocker handle per pole UL Recognized and CSA Certified

2 Second Decision		
Poles (Note A)		
Quick-Connect Terminals	Screw Terminals	Number of poles
1	6	Single pole unit
11	66	Two pole unit
111	666	Three pole unit
1111	6666	Four pole unit (Note D)

### 3 Third Decision

#### Internal Configuration

-0	Switch only (omit 4th and 5th decisions)
-1	Series
-1REC4	Auxiliary switch* .110 quick-connect
-1REG4	Auxiliary switch* (Gold Contacts) .110 quick-connect
-1REC5	Auxiliary switch* .187 quick-connect
-3	Shunt (up to 30 amperes only)
-4	Relay (up to 30 amperes only)

\*Only one auxiliary switch is normally supplied on two and three pole units. Can be used for solder terminals also. Switch is located in the right-hand pole (viewed from terminal end) unless otherwise specified. Multi-pole units with mixed construction, poles numbered left to right when viewed from terminal end.

### 4 Fourth Decision

#### Hz and Delay

-40	400Hz 150% instant trip
-41	400Hz short delay
-42	400Hz long delay
-43*	400Hz motor start
-49	400Hz 130% instant trip
-50	DC 150% instant trip
-51	DC short delay
-52	DC long delay
-53*	DC motor start
-59	DC 125% instant trip
-60	50/60Hz 150% instant trip
-61	50/60Hz short delay
-62	50/60Hz long delay
-600*	50/60Hz motor start delay
-64	50/60Hz, short delay (high pulse)
-65	50/60Hz, long delay (high pulse)
-66*	50/60Hz, motor start (high pulse)
-69	50/60Hz 125% instant trip
-71	DC, 50/60Hz short delay
-72	DC, 50/60Hz long delay
-73*	DC, 50/60Hz motor start delay

For addition of inertial delay, add an "F" to any delay number. \* Not available above 30 amperes.

### 7 Seventh Decision

#### Handle/Actuator Color\*\*

##### Toggle Handle Color †

-01	Black w/ white markings
-11	Yellow w/ black markings
-21	Red w/ white markings
-31	Blue w/ white markings
-41	Green w/ white markings
-91	White w/ black markings

##### Rocker/Actuator Color

-00	Black w/o markings
-01	Black w/ white markings
-02	Red w/o markings
-05	Opaque white w/o markings
-08	Gray w/o markings
-09	Translucent white w/o markings
-21	Red w/ white markings
-51	Opaque white w/ black markings
-81	Gray w/ black markings
-91	Translucent white w/ black markings

\*\*Not available for bat handle.

†Unmarked handles are available. Please consult factory.

Example:

UPG 1- 1REC4-61- 203- 09

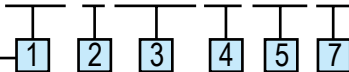

### 5 Fifth Decision

#### Rated Current (Note B)

Current Code	Ratings (Amps)	Current Code	Ratings (Amps)
-101	.100	-103	10.0
-251	.250	-153	15.0
-501	.500	-203	20.0
-751	.750	-303	30.0
-102	1.0	-353	35.0*
-252	2.5	-403	40.0*
-502	5.0	-503	50.0*
-752	7.5		

See page 122 for maximum voltage ratings. (\*Note C)

Standard current ratings listed. For other ratings, please consult factory.

### 6 Sixth Decision

#### Optional

-A	Metric thread mounting (Not available on APGN/UPGN) (Note F)
-B	Sub panel mount (Note E)
-C	277Vac 50/60Hz (Note G)
-H	International handle markings

One or more descriptions may be used as required. If this table is not used, go directly to the seventh decision.

## IPG DECISION TABLES

### How to Order

The ordering code for IPG circuit protectors may be determined by following the steps in the decision tables shown here.

The coding given permits a self-assigning part number but with certain limitations. Units with mixed ratings, combinations of styles, or constructions not listed in the third decision table, require a factory-assigned part number. With these, it is suggested that order entry be by description and/or drawings, and a part number will be established. Additionally, it is standard policy to establish a factory-assigned part number whenever a descriptive drawing exists to provide cross reference, traceability and manufacturing control.

When specifying a circuit protector for AC motor start or high inrush applications, the peak amplitude and surge duration should be specified for factory assistance in rating selection.

For example, the following is the code for a single pole IPG, quick-connect type terminal series unit with auxiliary switch, designed for operation in a 50/60Hz circuit. It has a short time delay and a rating of 20 amperes. Metric mounting inserts and a white handle are also specified.

To determine the ordering number for your particular IPG unit, simply follow the steps shown. You may use this number to place an order or as a reference for further questions you may have.

### Notes:

- A** It is recommended that power leads be soldered to protectors having push-on terminals for current trip ratings above 10 amperes.
- B** The standard current values for 100% of rated current are listed in the fifth decision table. Please consult an Airpax office or sales representative for other values.
- C** All IPG protectors meet normal requirements for moisture and salt spray resistance.
- D** UL recognized and CSA certified applications above 30 amperes are restricted to loads having a power factor of .75 minimum, and limited to 32Vdc only. VDE approval above 30 amperes is restricted to 32Vdc and 120Vac 50/60Hz. Standard terminals on ratings over 30 amperes are 10-32 screw type.
- E** When "A" is specified in the sixth decision in conjunction with IPG-6 type, metric screw terminals are supplied.

1 First Decision		
Type		
Type	Description	Std. Handle Color
IPG	Single pole with one handle per unit (Not available in multi-pole configuration)	Black
IPGH	Multi-pole with handle per pole	Black

2 Second Decision		
Poles		
Push-On Terminals	Screw Terminals	Number of poles
1	6	Single pole
11	66	Two pole
111	666	Three pole
1111	6666	Four pole

3 Third Decision	
Internal Configuration	
-0	Switch only (omit 4th and 5th decisions)
-1	Series
-1REG4	Auxiliary switch* .110 quick-connect
1REG4	Auxiliary switch* (Gold Contacts) .110 quick-connect
-1REG5	Auxiliary switch* .187 quick-connect
-3	Shunt (up to 30 amperes only)

\*Only one auxiliary switch is normally supplied on two and three pole units. Switch is located in the right-hand pole (viewed from terminal end) unless otherwise specified.

4 Fourth Decision Hz and Delay	
-40	400Hz 150% instant trip
-41	400Hz short delay
-42	400Hz long delay
-43*	400Hz motor start
-49	400Hz 130% instant trip
-50	DC 150% instant delay
-51	DC short delay
-52	DC long delay
-53*	DC motor start
-59	DC 125% instant trip
-60	50/60Hz 150% instant trip
-61	50/60Hz short delay
-62	50/60Hz long delay
-64	50/60Hz, short delay (high pulse)
-65	50/60Hz, long delay (high pulse)
-66*	50/60Hz, motor start (high pulse)
-69	50/60Hz 125% instant trip

For addition of inertial delay, add an "F" to any delay number.  
\* Not available above 30 amperes.

5 Fifth Decision Nominal Amperage Rating			
Current Code	Ratings (Amps)	Current Code	Ratings (Amps)
-101	.100	-103	10.0
-251	.250	-153	15.0
-501	.500	-203	20.0
-751	.750	-303	30.0
-102	1.0	-353	35.0*
-252	2.5	-403	40.0*
-502	5.0	-503	50.0*
-752	7.5		

See page 122 for maximum voltage ratings. (\*Note D)  
Standard current ratings listed. For other ratings, please consult factory.

6 Sixth Decision Optional	
-A	Metric thread mounting (Note E)

When this table is not used, table 7 may be substituted and U.S. thread will be supplied.

Example:

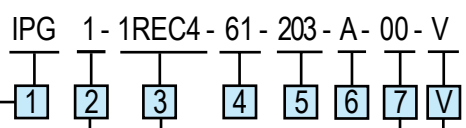

**V = VDE Approved**

The shaded areas denote VDE approval options. This approval requires the addition of a V at the end of the part number. The V will be added to any part number formed entirely from shaded decisions. If non-shaded areas are selected, the unit will not be VDE approved, but other approvals still apply.

7 Seventh Decision IPG and IPGH	
Toggle Handle Color	
-00	Black
-10	Yellow
-20	Red
-30	Blue
-40	Green
-90	White

